

Survival Guide

ADEMCO 4208SNF

8 zone serial polling loop expander
(6 class B and 2 class A zones)

-OR-

2 zone HW class A expander

8 zone serial polling loop mode -OR- Class A 2 HW zone expander mode

- Dip switches select all options
- Serial Learn **ONLY**
- Loops A-F (class B loops) use 10k EOLR (300 OHM tolerance)
- Fire zones require use of 610-13 10k EOLR
- Loops A and B optional fast response (10 msec)
- Loops G and H (class A loops) have built in 10k resistance (150 OHM tolerance per leg)
- Cover tamper available
- Powered by polling loop or external 12 VDC power source
- Dip switches have NO EFFECT
- Can only be used with panels that have 2k EOLR zones
- Loops G and H (class A zones) (Built in 10k resistance – 150 OHM tolerance)
- Loops A-F are non functional
- Cover tamper **NOT** available
- External 12 VDC required

U **L Agency Listings** **(Pending):**

- UL985 Household Fire
- UL1023 Household Burglary
- UL609 Commercial Burglary
- UL864 Commercial Fire
- CSFM
- FM
- MEA

When used as a HW 2 zone class A expander (Dip switches have no effect):

- 1 – Only Loops G and H are used (Loops A-F are non functional)
 - a: Do not use any resistors on loops G and H (10k resistance built into module)
- 2 – Can only be used **in this mode** with panels that use 2k EOLR and have a grounded return.
- 3 – Must be powered from an external 12VDC power source
- 4 – Must be placed inside cabinet to meet UL requirements (cover tamper is disabled in this mode)
- 5 - Addendum dated 7/98 requires wiring changes for this mode (Changes from original configuration shown in boxes)

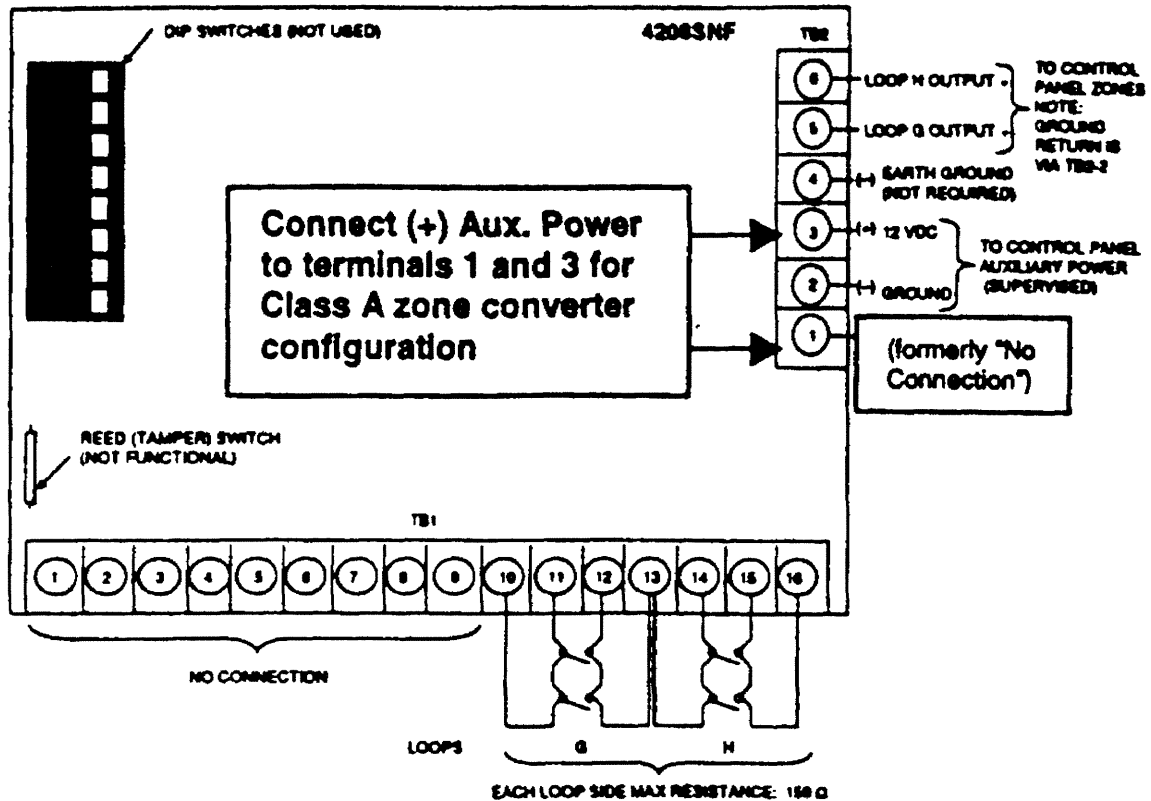

Figure 2: Summary of Connections – Class B to Class A Zone Converter

Voltage readings:

TB1: Loops G and H: 8.3 VDC

TB2 Terminals:

- 1(+) and 2(-): 13.7 VDC
- 2(-) and 3(+): 13.7 VDC
- 5(+) and common on panel zone: 6.4 VDC
- 6(+) and common on panel zone: 6.4 VDC

Current draw:

22 mA

4208 SNF zone expander

Can be used as an 8 zone serial polling loop expander (6 class B and 2 class A zones)

-OR-

an HW 2 zone class A expander

In the box:

Installation Instructions (document # K3179)

4208 SNF module circuit board (p# SA4208SNF)

Mounting box (p# N5620)

Mounting box cover (p# N5621)

Mounting box cover tamper magnet (p# N5700)

8 x standard 10k resistors (p# P1002)

6 x 610-13 10k resistors (shrink wrapped res. with a 6 inch wire lead attached to each leg)

Compatible panels:

- In the 8 zone expander mode: All panels that support serial learn polling loop devices
- In the 2 zone HW class A zone expander mode: any panel with 2k EOLR zone input

Possible installer problem areas:

- 1 – 8 dip switches that set 4 different parameters (8 zone expander mode)
- 2 – Installer must select **one of four** serial number charts to use in zone assignment (selected by dip switch settings)
- 3 – Module wiring to panel is completely different in the 8 zone expander roll and the HW 2 zone mode
- 4 - Installers might add resistors to loops G and H even though the loops have built in 10 k resistance **OR** installers might add 2k resistor to positive side lead from expander to panel when used in 2HW class A zone mode
- 5 - Special loop configuration of loops G and H may cause zone wiring hook up problems
- 6 - In the 8 zone expander mode, zones are programmed as Serial Polling Loop Device
- 7 - In the 2 zone HW mode, the expander zones are tied to the positive side of HW zones on the panel

When used as an 8 zone polling loop expander (serial learn ONLY):

- 1 - You have 6 class B zones (loops A-F) and 2 class A zones (loops G and H)
 - a: Loops A - F use 10k EOLR with 300 ohm tolerance
 - 1: For BURG zones use standard 10k resistors – for FIRE zones you **MUST** use 610-13 10k resistors to meet UL requirements
 - b: Loops G and H have 10k resistance built into the module with 150 ohm tolerance per side (Do **NOT** use external resistors on loops G and H)
- 2 – Loops A and B can optionally be programmed for fast 10 msec response via dip switch #1 (as opposed to normal 400msec)
- 3 – Module can be powered by the polling loop or with an external 12 VDC power source
- 4 – Unit can be mounted inside cabinet **OR** remotely with cover tamper enabled

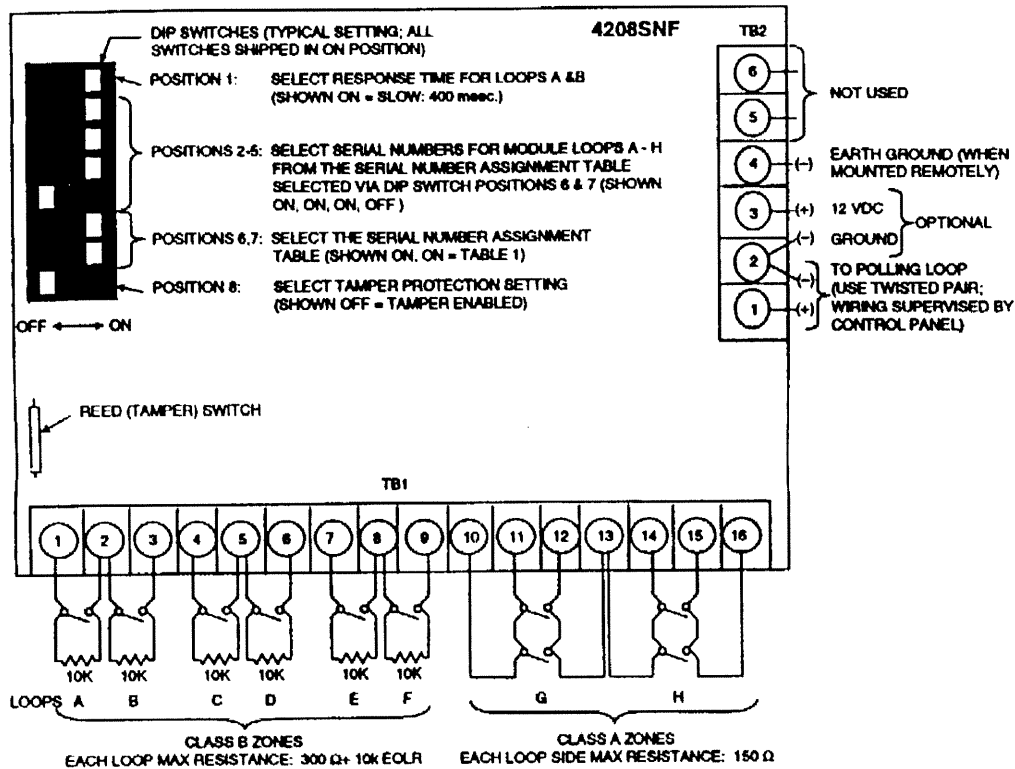

Figure 1: Summary of Connections – Zone Expander

Voltage readings:

TB1: Loops A-F: 5.3 VDC
 Loops G and H: 5.7 VDC

TB2 Terminals:

1(+) and 2(-): 8 – 10 VDC
IF USED 2(-) and 3(+): approx. 13 VDC

Current draw:

- Polling loop only:
 33.6 mA
 - With external power supply:
 0.6 mA from polling loop
 33 mA from external pwr